

Manual Supplement

Manual Title: 525A Users
Print Date: August 2001
Revision/Date: 1, 10/01

Supplement Issue: **2**
Issue Date: 8/03
Page Count: 9

This supplement contains information necessary to ensure the accuracy of the above manual. This manual is distributed as an electronic manual on the following CD-ROM:

CD Title: 525A Users
CD Rev. & Date: 2, 4/2002
CD PN: 1601552

Change #1

On page 1-2, Table 1-1, replace the Resistance row with the following:

Resistance	0 to 4000 Ω (4-Wire)	5 to 4000 Ω (2-Wire)
------------	-----------------------------	-----------------------------

Under Options and Accessories, replace the third bullet with the following:

- Fluke 700 and 525A-PXX series pressure modules

On page 1-11, Figure 1-4, replace the illustration with the following:

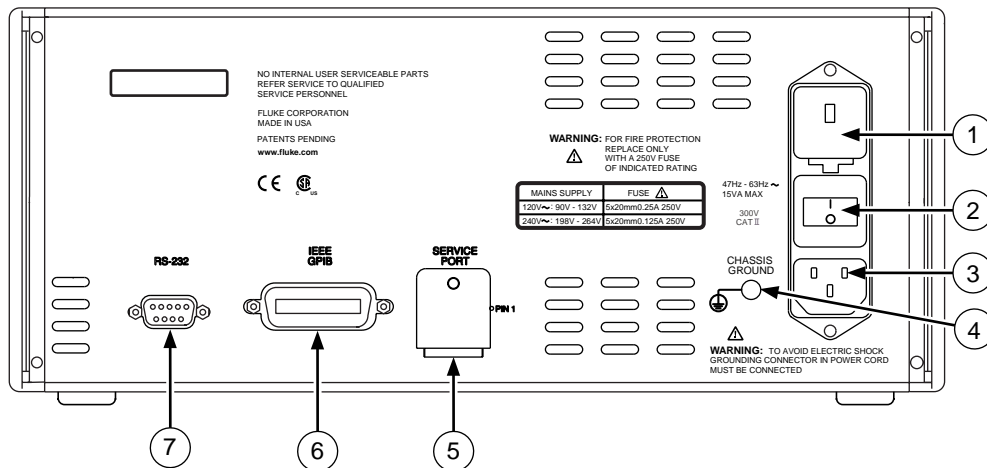

ajr10F.eps

On page 2-2, change the heading,

From: **Simulating Temperature Using a Thermocouple**

To: **Simulating Thermocouple Temperature**

Replace step 1 with the following:

1. Attach the thermocouple extension wire as shown in Figure 2-1. One pin is wider than the other. Do not try to force a miniplug in the wrong polarization.

Change the figure title,

From: **Figure 2-1. Connection to Simulate Temperature Using a Thermocouple**

To: **Figure 2-1. Connection to Simulate Thermocouple Temperature**

On page 3-1, under **Using Input Mode**, replace the first paragraph with the following:

In Input mode, the Calibrator measures resistance, and temperature from RTD and thermocouple sensors and displays pressure measurements from Fluke 700 and 525A-PXX series pressure modules.

On page 3-2, under **Measuring Temperature Using Thermocouples**, add the following sentence after the second sentence in the second paragraph:

External cold junction reference is 0 °C or 32 °F.

On page 3-3, replace Figure 3-2 with the following:

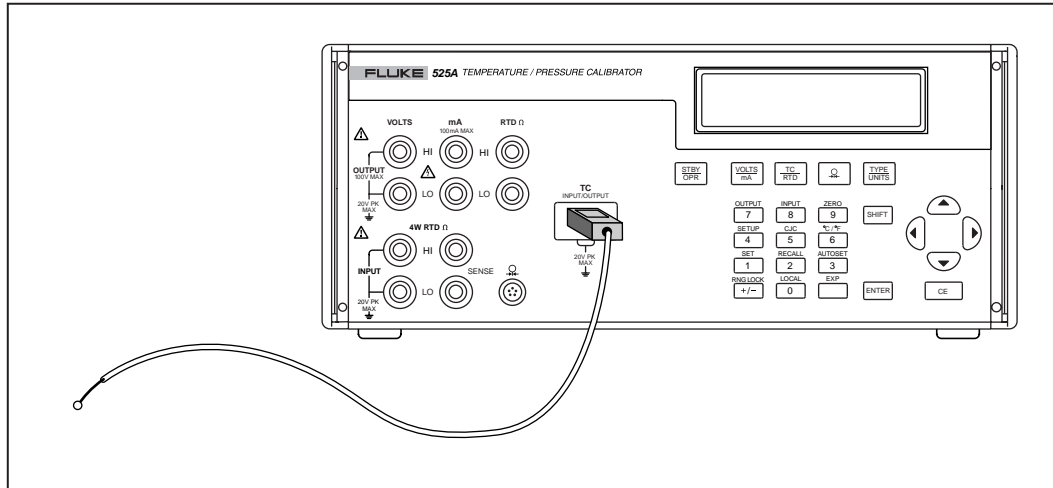

Figure 3-2. Measuring Temperature with a Thermocouple

ajr07f.eps

On page 3-5, change the figure title,

From: **Figure 3-3. Measuring Temperature Using RTDs**
 To: **Figure 3-3. Measuring RTD Output from an Instrument**

On page 6-4, Table 6-2, under Recommended Model,

Change: Wavetek 1281 w/option 20 (ohms converter)
 To: 8508A or Wavetek 1281 w/option 20 (ohms converter)

Add the following entries to Table 6-2:

Dewar Flask with lid	—	Thermocouple tests
Characterized Type J Thermocouple	—	Thermocouple tests
Banana Jack to Copper TC Mini-Connector Cable	—	Thermocouple tests

On page 6-6, under **Testing DC Current**, replace the paragraph, Figure 6-2, and Table 6-3 with the following:

Use the 8508A and the precision shunt to measure the 525A output as shown in Figure 6-2. Take the Voltage reading from the 8508A and divide it by the 742A-1 actual value to determine the current output.

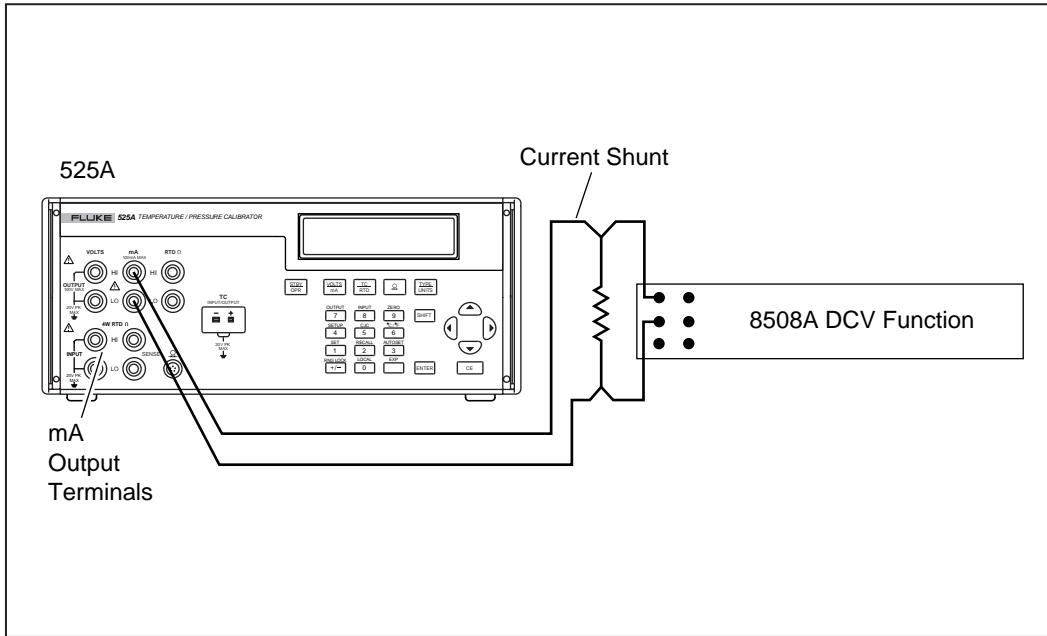

Figure 6-2. Measuring DC Current

ajr25f.eps

Table 6-3. Measuring DC Current

100 mA Output (mA)	Volt	Current (I=E/R)	742A-1 Shunt Value	90 Day (µA) Spec	1 Year (µA) Spec
0.000			Direct into 8508A Current Input, Autorange	2.0	2.0
25.000				4.1	4.5
75.000				8.3	9.5
100.000				10.5	12.0

On page 6-7, replace the two paragraphs, Figure 6-3, and Table 6-4 with the following:

For this test the TC mV specifications will be used. When this test is combined with the CJC test all functions of the TC output will have been checked. Typically, the cable need to connect the 525A to the 8508A will need to be fabricated. The TC mini-connector will need Copper-Copper (White), using Copper wire connect the TC Mini-Connector to standard Banana Jacks. See Figure 6-3 for a connection diagram.

For this test, the CJC (Cold Junction Compensation) must be turned off. Press (Shift) then (5) to turn off the CJC, XCJC on the display indicated that the CJC is turned off. Select TC, Output by pressing (shift) then (7), Press (Type/Unit) until mV/°C is shown on the display. Output the mV values listed in Table 6-4.

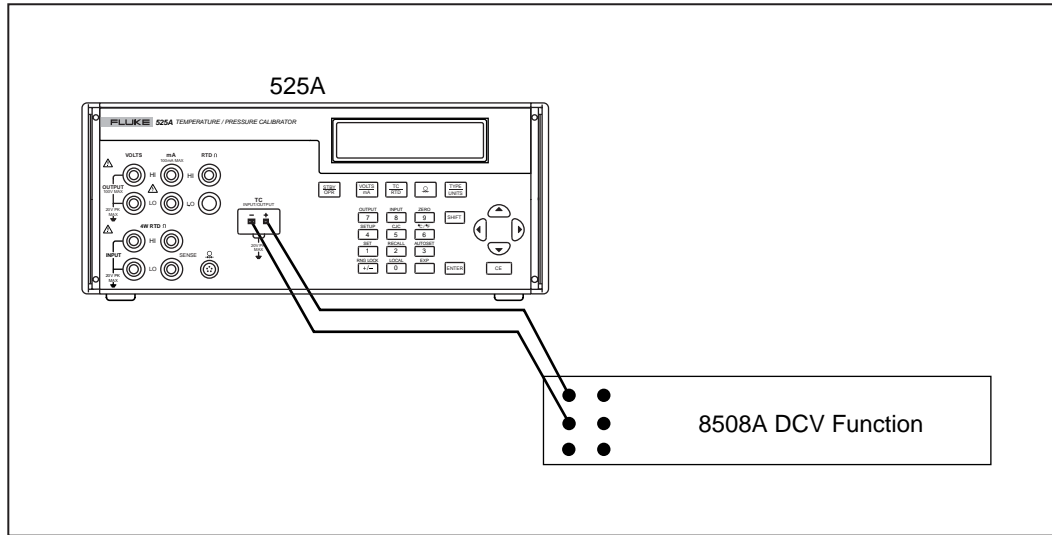

Figure 6-3. Testing TC Output

ajr26f.eps

Table 6-4. TC mV

Nominal Voltage (mV)	90-Day Spec. (μV)	1-Year Spec. (μV)
-5.000	3.125	3.15
15.00	3.375	3.45
30.00	3.75	3.9
50.00	4.25	4.5
70.00	4.75	5.1

On page 6-8, replace the CJC Calibration section with the following:

Testing CJC (Cold Junction Compensation)

Connect a Type-J thermocouple to the TC terminal on the 525A. Immerse the thermocouple and a precision thermometer into a mineral oil lag bath. The test set-up is shown in Figure 6-5.

Verify that the readings of the 525A and the precision thermometer are within the Type-J specifications.

The 90-day spec is 0.14°C

The 1-year spec is 0.16°C

Note

Typical Type-J thermocouples do not have specifications accurate enough to be used as a standard, to maintain a good Test Uncertainty Ratio (TUR) a characterized Type-J thermocouple may need to be used

On page 6-9, replace the paragraph and Figure 6-5 with the following:

Testing Thermocouple Input

Set the 525A to TC input by pressing (Shift) then (8). All 525A conditions will be the same as the Thermocouple Output test, CJC off, mV/°C mode. Connect the 525A to the 5520A as shown in Figure 6-4. Set the 5520A to output the mV values in Table 6-4.

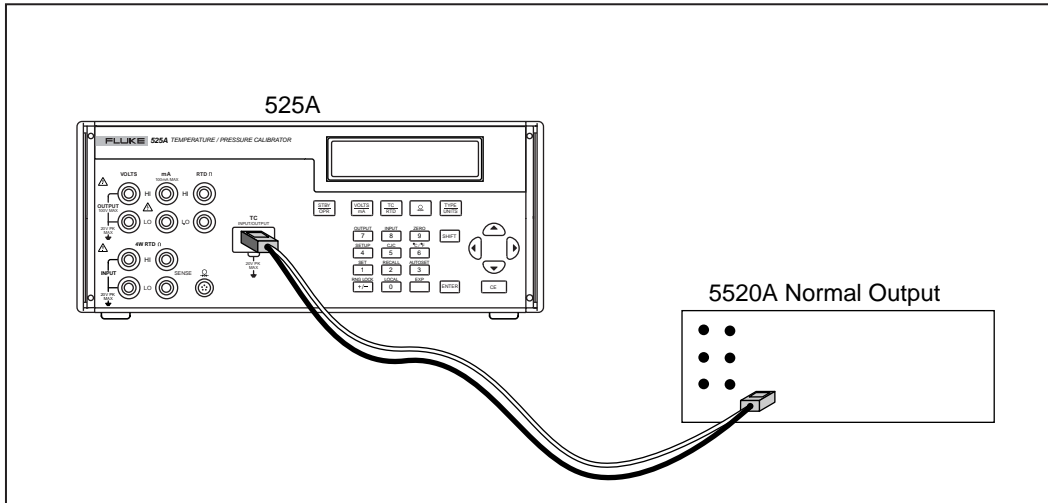

Figure 6-5. Connections for Measuring TC Input

aj24f.eps

On page 6-10, under **Testing Ohms Output**, delete the last two sentences in the paragraph, and replace the Note, and Figure 6-6 with the following:

Note

The 8508A must be in the "loI (low current mode) when measuring 5 ohms in the 4 K ohm range or an overload will occur.

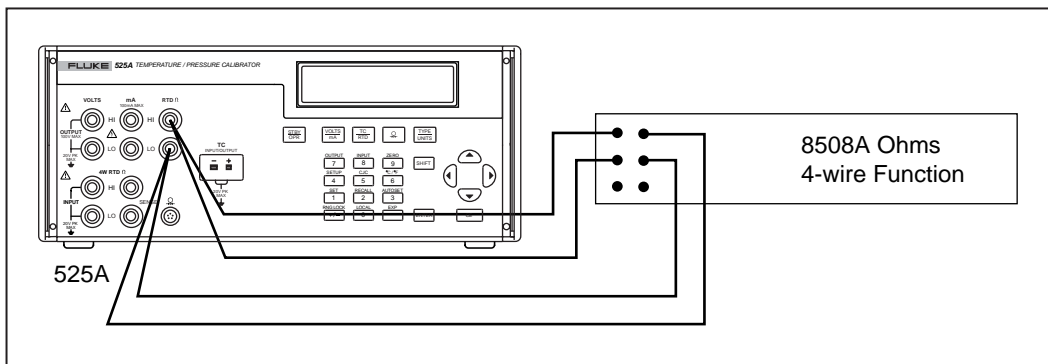

Figure 6-6. Connecting for Measuring Resistance Output

aj23f.eps

On page 6-11, Table 6-5, under the 1 Year column, add 0.03 to the 100 Output and add 0.3 to the 1000 Output entries.

On page 6-12, under **Testing Ohms Input**, replace the paragraph and Figure 6-7 with the following:

Before measuring ohms input, you need to "characterize" the ohms output of a 5520A. To achieve the needed accuracy, the 8508A will be used as a transfer standard and the 742A will be used as the reference standard. To find the true value of the 5520A output, use the ratio input function of the 8508A located on the front and rear panels. Connect the 742A to the front terminal and connect the 5520A to the rear terminals, both using four-wire measure. See Figure 6-7 for a connection diagram.

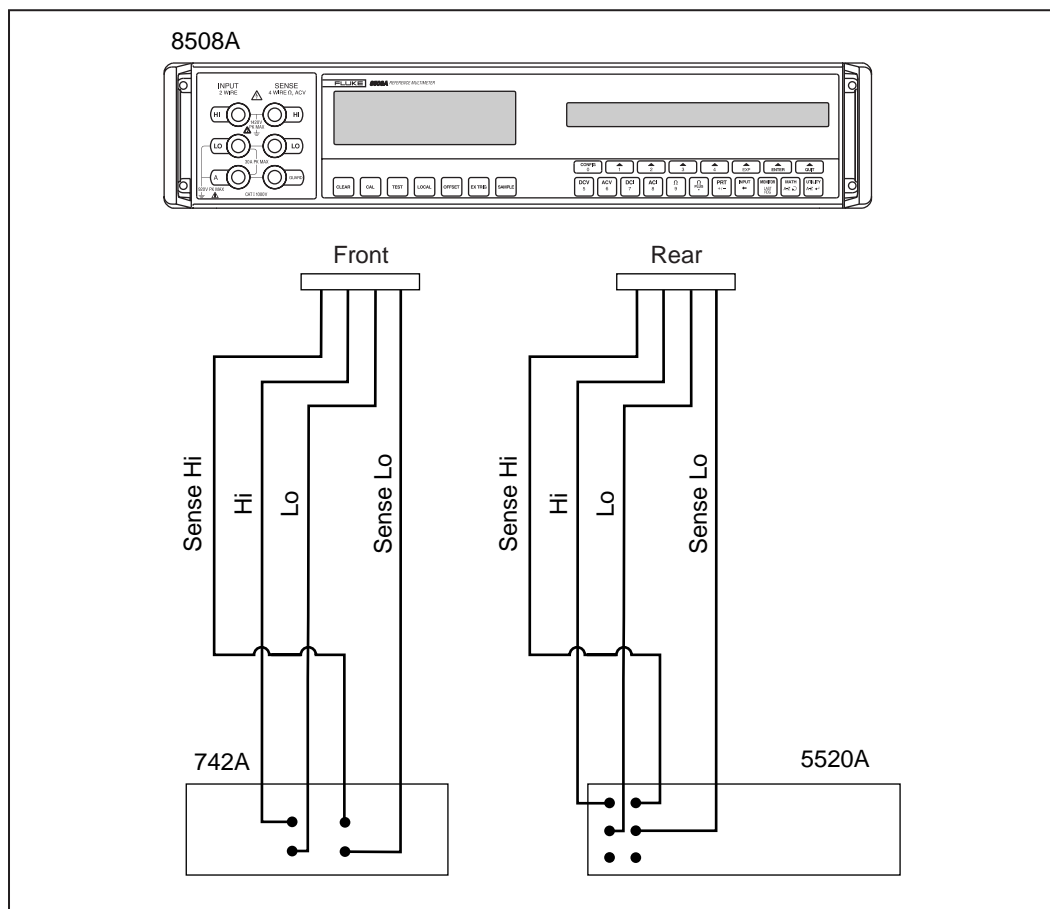

Figure 6-7. 8508A Connection Diagram

ajr28f.eps

On page 6-13, replace the second and third sentences in the paragraph with the following:

For more information on the correct usage of ratio mode refer to the 8508A Operators Manual. Use Table 6-8 to note the ratio indication on the 8508A.

Add the following 90-Day Spec and 1 Year Spec columns to Table 6-6,

Range (Ω)	90 Day Spec (Ω)	1 Year Spec (Ω)
400		
0.000	0.003	0.003
100.000	0.0065	0.007
200.000	0.010	0.011

300.000	0.0135	0.015
400.000	0.017	0.019
4000		
0.00	0.03	0.03
1000.00	0.065	0.07
2000.00	0.10	0.11
3000.00	0.135	0.15
4000.00	0.17	0.19

On page 6-14, under **Testing Pressure Modules**, replace the paragraph with the following:

The Fluke 700 and 525A-P series pressure modules are calibrated separately for the 525A. The calibration follows the pressure module, so only a performance test is needed. Connect any of the Fluke 700 and 525A-P series pressure modules to the pressure module connector. Verify that the 525A reads pressure.

On page 6-17, Table 6-7, add item 27 to the table:

27	Lable, Cover, GPIB	200870
----	--------------------	--------

On page 6-19, Table 6-9, replace the entire table with the following:

Table 6-9. Fluke 6100 Series Pressure Modules

Fluke Model	Range	Type
Fluke 525A-P02	1 psid to 6900 Pa	Differential, dry
Fluke 525A-P05	30 psi to 207 kPa	Gage, wet
Fluke 525A-P06	100 psi to 690 kPa	Gage, wet
Fluke 525A-P07	500 psi to 3400 kPa	Gage, wet
Fluke 525A-P08	1000 psi to 6900 kPa	Gage, wet
Fluke 525A-P29	3000 psi to 20.7 MPa	Gage, wet
Fluke 525A-PA6	100 psia to 690 Kpa	Absolute, wet
Fluke 525A-PA7	500 psia to 3400 kPa	Absolute, wet
Fluke 525A-PV4	15 psi to - 103 kPa	Vacuum, dry
Fluke 525A-PA4	15 psia to 103 kPa	Absolute, wet

On page 7-3, under **Resistance Specifications, Input**, add the following footnote to Ranges,

Ranges¹
1. 4-Wire only

On pages 7-4 and 7-5, replace the entire **Thermocouple Specification, Output and Input** table with the following:

Thermocouple Specification, Output and Input

TC Type	Range (° C)		Absolute Uncertainty, tcal ±5 °C, ±(°C) ¹	
			Output/Input	
	Minimum	Maximum	90 days	1 year
B	600 °C	800 °C	0.42 °C	0.46 °C
	800 °C	1000 °C	0.39 °C	0.39 °C
	1000 °C	1550 °C	0.40 °C	0.40 °C
	1550 °C	1820 °C	0.44 °C	0.45 °C
C	0 °C	150 °C	0.25 °C	0.30 °C
	150 °C	650 °C	0.21 °C	0.26 °C
	650 °C	1000 °C	0.23 °C	0.31 °C
	1000 °C	1800 °C	0.38 °C	0.50 °C
E	1800 °C	2316 °C	0.63 °C	0.84 °C
	-270 °C	-100 °C	0.38 °C	0.50 °C
	-100 °C	-25 °C	0.16 °C	0.18 °C
	-25 °C	350 °C	0.14 °C	0.15 °C
J	350 °C	650 °C	0.14 °C	0.16 °C
	650 °C	1820 °C	0.16 °C	0.21 °C
	-210 °C	-100 °C	0.20 °C	0.27 °C
	-100 °C	-30 °C	0.18 °C	0.20 °C
K	-30 °C	150 °C	0.14 °C	0.16 °C
	150 °C	760 °C	0.14 °C	0.17 °C
	760 °C	1200 °C	0.18 °C	0.23 °C
	-270 °C	-100 °C	0.25 °C	0.33 °C
L	-100 °C	-25 °C	0.19 °C	0.22 °C
	-25 °C	120 °C	0.14 °C	0.16 °C
	120 °C	1000 °C	0.19 °C	0.26 °C
	1000 °C	1372 °C	0.30 °C	0.40 °C
N	-200 °C	-100 °C	0.37 °C	0.37 °C
	-100 °C	800 °C	0.26 °C	0.26 °C
	800 °C	900 °C	0.17 °C	0.17 °C
R	-270 °C	-100 °C	0.33 °C	0.40 °C
	-100 °C	-25 °C	0.20 °C	0.24 °C
	-25 °C	120 °C	0.16 °C	0.19 °C
	120 °C	410 °C	0.14 °C	0.18 °C
R	410 °C	1300 °C	0.21 °C	0.27 °C
	-50 °C	250 °C	0.58 °C	0.58 °C
	250 °C	400 °C	0.34 °C	0.35 °C
	400 °C	1000 °C	0.31 °C	0.33 °C
R	1000 °C	1767 °C	0.30 °C	0.40 °C

S	0 °C	250 °C	0.56 °C	0.56 °C
	250 °C	1000 °C	0.36 °C	0.36 °C
	1000 °C	1400 °C	0.30 °C	0.37 °C
	1400 °C	1750 °C	0.35 °C	0.46 °C
T	-270 °C	-150 °C	0.51 °C	0.63 °C
	-150 °C	0 °C	0.18 °C	0.24 °C
	0 °C	120 °C	0.13 °C	0.16 °C
	120 °C	400 °C	0.12 °C	0.14 °C
U	-200 °C	0 °C	0.56 °C	0.56 °C
	0 °C	600 °C	0.27 °C	0.27 °C
mV	-10 to 75.000 mV			
1. Does not include thermocouple wire error.				

On page 7-10, under **Pressure Measurement**, replace the first sentence with the following:

The Calibrator can accept either the Fluke 700 or 525A-P series pressure modules.

Change #2

On pages 4-24, 4-25, 4-28, and 5-2, replace all occurrences of "ERR?" with "FAULT?"

On page 4-27, under CME and EXE, replace both entries with the following:

CME Command error. The 525A's IEEE-488 interface encountered an incorrectly formed command. (The command FAULT? fetches the latest code in the error queue, which contains error codes for the first 15 errors that have occurred.)

EXE Execution error. An error occurred while the 525A tried to execute the last command. This could be caused, for example, by a parameter being out of range (The command FAULT? fetches the latest code in the error queue, which contains error codes for the first 15 errors that have occurred.)

On page 5-4, under Status Commands, replace the ERR? entry with the following:

FAULT?	Returns the latest error code from the error queue, then removes that error code from the queue.
--------	--

On page 5-7, add the following between ***ESR?** and **FUNC?**:

FAULT? IEEE-488 RS-232 Sequential Overlapped

Returns the latest error code from the error queue. If the queue is empty (no errors have occurred) it returns 0. The command can be used when the previous command did not do what it was intended to do.

For example, if a value for current output above 100 mA is entered, the FAULT? command would return error code 105, entry is above upper limit for the selected output range.

On page 5-20, under ***TST**, replace "ERR?" entry with "FAULT?"